



# CSSD furniture & small equipment

Complete workflow solutions



**Miele**

Group  
Member



# CSSD Furniture and small equipment

## Complete workflow solutions

Properly designed central sterilization departments facilitate the efficient one-way flow of instruments between soiled, clean and sterile areas, reduce the risks to staff and patients of cross contamination whilst providing an optimal work environment.

The items in this brochure have been carefully selected from Steelco's extensive experience in supplying complete CSSD solutions.

## Driven by customer needs

Steelco is a leading infection control solution provider, supplying the healthcare, laboratory research and pharma sectors. Active in over 100 countries, Steelco has equipped numerous world renown hospitals and counts among its customers household names in the laboratory, pharmaceutical and industrial sectors.

Driven by customer feedback, Steelco develops, manufactures and supplies solutions that maximize infection control safety, optimize processes and minimize costs. Our focus on innovation has led us to become leaders in areas such as automation.

Whether you are just wishing to replace a single small machine or designing and equipping a large central CSSD, Steelco and it's factory trained distributors are here to help you make the best decision possible that works for you and then support you every step of the way.



## SOILED GOODS AREA

- Manual cleaning workstations p. 7
- Wall and floor cabinets p. 9
- Accessories p. 12
- Small ultrasonic cleaners p. 16

## CLEAN AREA

- Packing tables p. 19
- Accessories to configure workstations p. 23
- Tables for general use p. 24
- Pouch sealers p. 25

## STERILE AREA

- Mobile open storage and transportation p. 29
- Closed instrument carts p. 33
- Shelving systems p. 37
- Filing and pass-through cabinets p. 43



## Complete workflow solutions to meet customer needs

Whether working in a small clinic, a large centralised CSSD or an outsourced reprocessing centre, having efficient and reliable equipment is only part of the solution.

Steelco provides complete workflow solutions from when an instrument is used on a patient, through transportation, manual and automated cleaning, inspection, packaging, sterilization, storage and transportation, delivered ready and safe for use again.

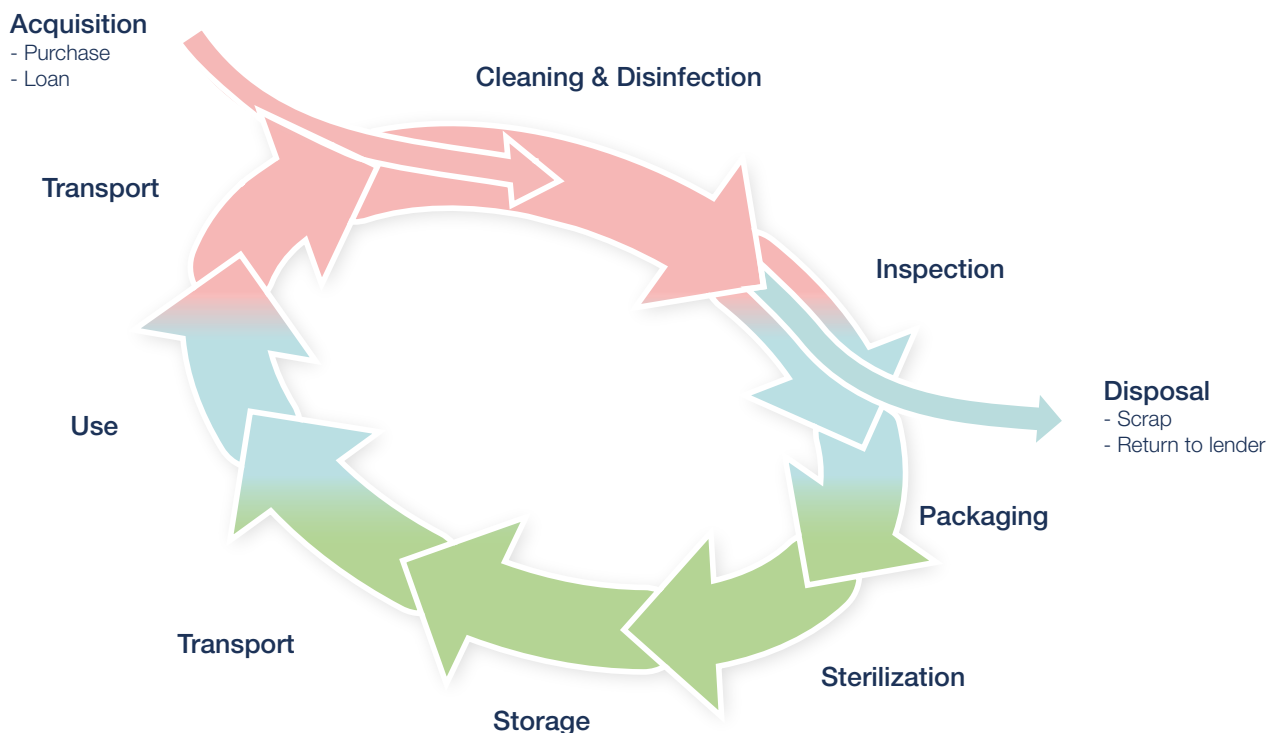

## Layout design and planning to unlock the power of the best equipment

Steelco understands that all CSSD facilities are different in terms of size, layout configuration, type and volume of instruments being reprocessed, level of automation, staffing levels as well as local regulations and work practices.

We appreciate that you are not buying a single piece of equipment, accessory or consumable. You expect that any investment in your facility, however large or small will help towards improving your goal of having the right instrument, at the right time in the right place that is safe to use, all whilst staying within budget.

With the development of minimal invasive and robotic surgery instrumentation, CSSDs need to reprocess increasingly complex lumen instruments. By working closely with instrument manufacturers, Steelco can provide safe and efficient reprocessing solutions for complex instruments.

## A comprehensive range of equipment and accessories to maximize performance

This brochure contains the elements needed for designing the optimal solution for equipping individual facilities with furniture, small equipment and accessories specifically designed to comply with standards and work practices found in modern CSSDs.

Chapters are divided into the 3 zone CSSD barrier system:

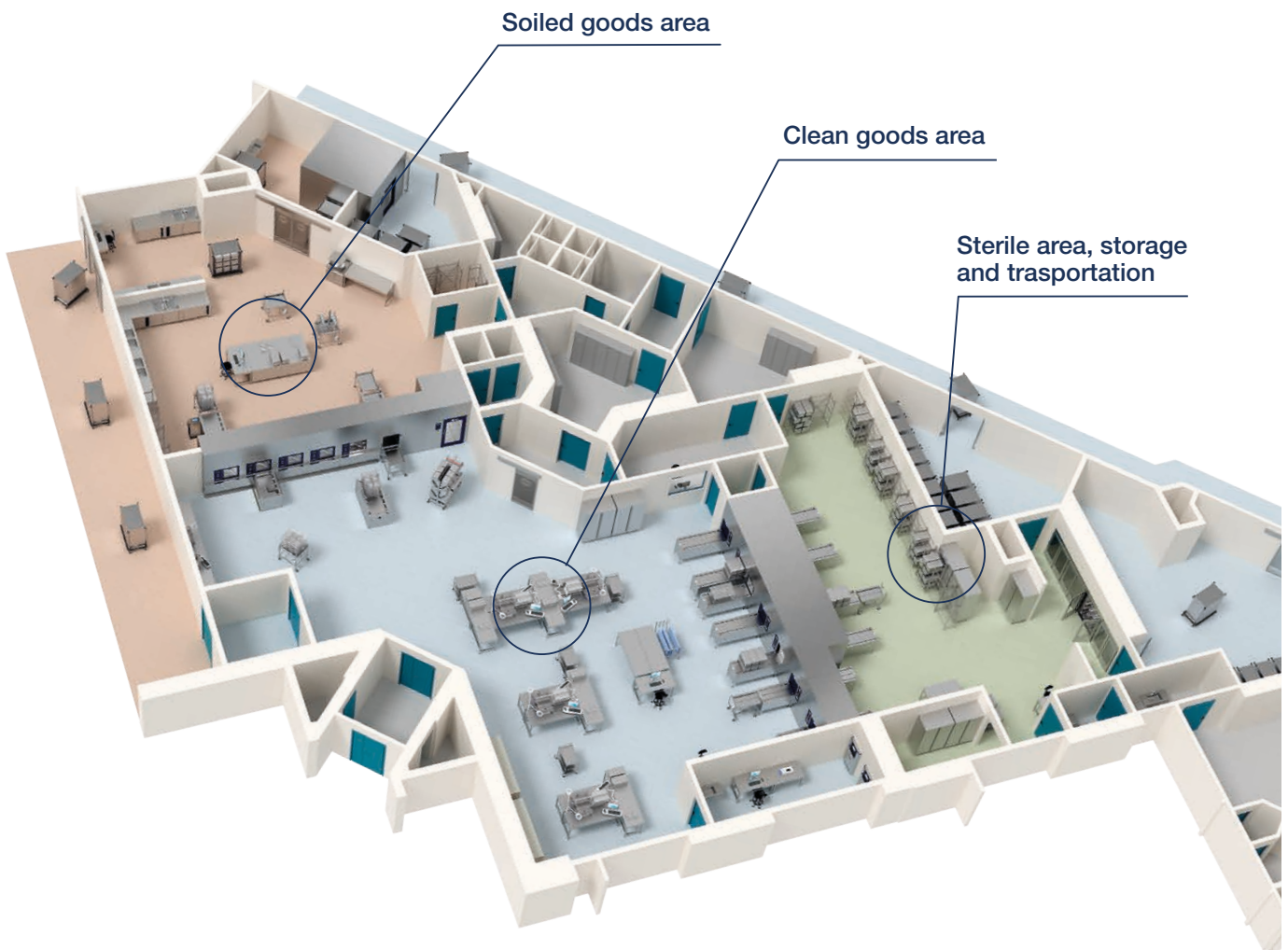

Our team of planners has considerable experience in designing solutions that cover both new build and refurbishing current facilities. We can either use existing client drawings or prepare new proposals to best meet a customer's expectations whilst respecting budget needs.

Steelco has an especially strong track record in undertaking complex automation projects or customizing solutions in existing departments with architectural challenges



## SOILED GOODS AREA

Soiled instruments and other used goods arrive from the operating room, wards and various departments in containers and baskets. Department layouts are designed to handle different type of goods and reprocessing requirements which may include manual cleaning and ultrasonic processing prior to cleaning and disinfection in washers and cart washers.

Furniture in this wet area is of the highest quality AISI 304 stainless steel and TIG welded for seamless smooth edges that are easy to clean and includes:

- Manual cleaning workstations
- Wall and floor cabinets
- Small equipment and accessories



## Manual cleaning workstations

Steelco's modular system is flexible and designed around operator workflow. Stainless steel units are factory built and delivered pre assembled according to customer specifications for easy onsite installation.

### Wall cabinet units

A choice of single or double width stainless steel 400mm - 15 3/4" deep wall cabinets feature a variable height shelf for easy access. Available as open wall units or fitted with either sliding or hinged doors that are handle free to eliminate dirt traps and ease cleaning.

### Sink units

Two sink sizes in either single or double configuration can be seamlessly integrated into the centre or left or right hand side of worktops. A choice of faucets can be specified as well as water/air guns or a sink dosing system that monitors correct detergent dosing and water temperature.



### Worktops and built in ultrasonic units

A stainless steel worktop is in either 600mm - 23 5/8" or 700mm - 27 9/16" depth, matching the length of base cabinets. A built in ultrasonic unit can be factory fitted for a smooth integrated finish.

### Base units

600mm - 23 5/8" and 700mm - 27 9/16" depth, open, hinged or sliding door base units. Also available with 3 or 4 drawers.



## CREATING A WET AREA WORK STATION

To ensure the right workstation configuration, it is important to plan the tasks that will be performed and the flow of dirty instrument before loading them into automatic washer disinfectors. Steelco's factory trained distributors can work with you and also rely on the support of Steelco's layout planning department to configure workstations to best meet your needs.

### Step 1 Choose depth and design of the base cabinets

Select base cabinets: open design or with a choice of sliding or hinged doors or drawer system. Separate versions available depending whether unit(s) will contain a sink(s). Cabinets for sinks have dedicated catalogue numbers, do not contain a shelf and have a cut out for piping.

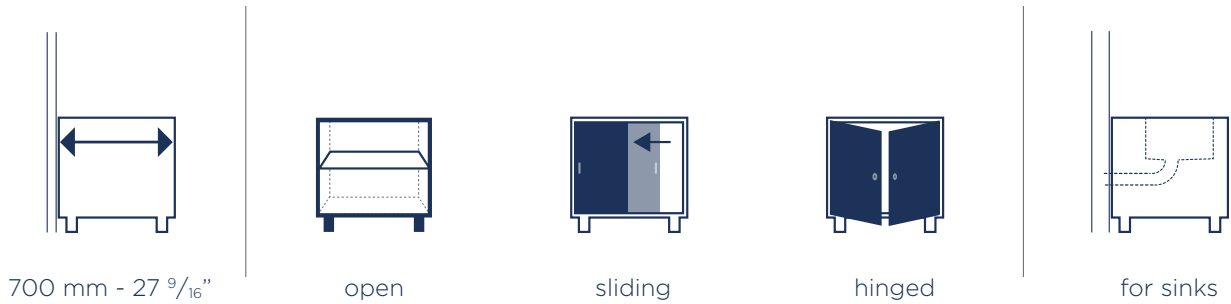

### Step 2 Select sinks

Number, size and location of sinks in the workstation.

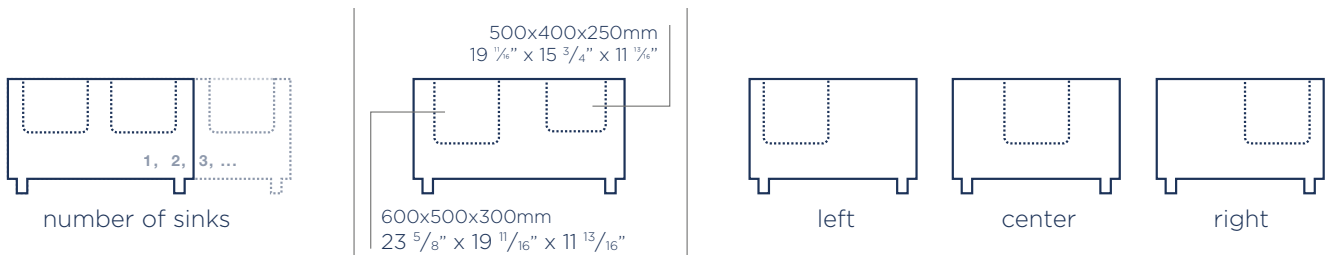

### Step 3 Select accessories

Type of faucet, spray guns and other accessories such as built in ultrasonic unit.

### Step 4 Select worktop and kickplate

Select worktop length as total length of cabinets. Standard worktop splash guard is 100mm - 3 <sup>15</sup>/<sub>16</sub>" high. Add a kickplate if needed in the same length as cabinets and any open ends.

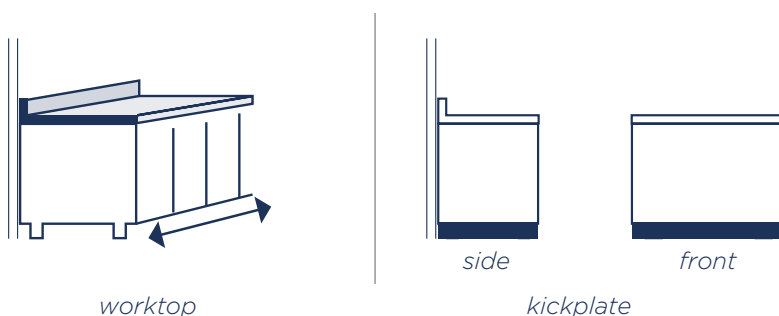

## WALL CABINETS

A choice of single or double width stainless steel 400mm - 15<sup>3</sup>/<sub>4</sub>" deep cabinets feature a variable shelf for easy access. Available as open wall units or fitted with either sliding or hinged doors that are handle free to eliminate dirt traps and ease cleaning.

### Open wall cabinets

code	description
999CAW000546	Open wall cabinet, 1 adjustable shelf 500x400x600mm - 19 <sup>11</sup> / <sub>16</sub> "x15 <sup>3</sup> / <sub>4</sub> "x23 <sup>5</sup> / <sub>8</sub> "
999CAW000646	Open wall cabinet, 1 adjustable shelf 600x400x600mm - 23 <sup>5</sup> / <sub>8</sub> "x15 <sup>3</sup> / <sub>4</sub> "x23 <sup>5</sup> / <sub>8</sub> "
999CAW001046	Open wall cabinet, 1 adjustable shelf 1000x400x600mm - 39 <sup>3</sup> / <sub>8</sub> "x15 <sup>3</sup> / <sub>4</sub> "x23 <sup>5</sup> / <sub>8</sub> "
999CAW001246	Open wall cabinet, 1 adjustable shelf 1200x400x600mm - 47 <sup>1</sup> / <sub>4</sub> "x15 <sup>3</sup> / <sub>4</sub> "x23 <sup>5</sup> / <sub>8</sub> "



### Hinged single and double door wall cabinets

999CAWH00546	Wall cabinet, 1 hinged door, 1 adj. shelf 500x400x600mm - 19 <sup>11</sup> / <sub>16</sub> "x15 <sup>3</sup> / <sub>4</sub> "x23 <sup>5</sup> / <sub>8</sub> "
999CAWH00646	Wall cabinet, 1 hinged door, 1 adj. shelf 600x400x600mm - 23 <sup>5</sup> / <sub>8</sub> "x15 <sup>3</sup> / <sub>4</sub> "x23 <sup>5</sup> / <sub>8</sub> "
999CAWH01046	Wall cabinet, 2 hinged doors, 1 adj. shelf 1000x400x600mm - 39 <sup>3</sup> / <sub>8</sub> "x15 <sup>3</sup> / <sub>4</sub> "x23 <sup>5</sup> / <sub>8</sub> "
999CAWH01246	Wall cabinet, 2 hinged doors, 1 adj. shelf 1200x400x600mm - 47 <sup>1</sup> / <sub>4</sub> "x15 <sup>3</sup> / <sub>4</sub> "x23 <sup>5</sup> / <sub>8</sub> "



### Sliding single and double door wall cabinets

999CAWS01046	Wall cabinet, sliding doors, 1 adjustable shelf 1000x400x600mm - 39 <sup>3</sup> / <sub>8</sub> "x15 <sup>3</sup> / <sub>4</sub> "x23 <sup>5</sup> / <sub>8</sub> "
999CAWS01246	Wall cabinet, sliding doors, 1 adjustable shelf 1200x400x600mm - 47 <sup>1</sup> / <sub>4</sub> "x15 <sup>3</sup> / <sub>4</sub> "x23 <sup>5</sup> / <sub>8</sub> "



## BASE CABINET UNITS

700mm (27<sup>5</sup>/<sub>9</sub> inches) depth open, hinged or sliding door base units.  
600mm (23<sup>5</sup>/<sub>8</sub> inches) depth open available in price list.

### Open base unit with adjustable shelf

code	description
999CAB000578	500 x 700 x 860mm - 19 <sup>11</sup> / <sub>16</sub> " x 17 <sup>9</sup> / <sub>16</sub> " x 33 <sup>7</sup> / <sub>8</sub> "
999CAB000678	600 x 700 x 860mm - 23 <sup>5</sup> / <sub>8</sub> " x 17 <sup>9</sup> / <sub>16</sub> " x 33 <sup>7</sup> / <sub>8</sub> "
999CAB001078	1000 x 700 x 860mm - 39 <sup>3</sup> / <sub>8</sub> " x 17 <sup>9</sup> / <sub>16</sub> " x 33 <sup>7</sup> / <sub>8</sub> "
999CAB001278	1200 x 700 x 860mm - 47 <sup>1</sup> / <sub>4</sub> " x 17 <sup>9</sup> / <sub>16</sub> " x 33 <sup>7</sup> / <sub>8</sub> "



### Base unit with hinged door(s) and adjustable shelf

code	description
999CABH00578	500 x 700 x 860mm - 19 <sup>11</sup> / <sub>16</sub> " x 17 <sup>9</sup> / <sub>16</sub> " x 33 <sup>7</sup> / <sub>8</sub> ", 1 door
999CABH00678	600 x 700 x 860mm - 23 <sup>5</sup> / <sub>8</sub> " x 17 <sup>9</sup> / <sub>16</sub> " x 33 <sup>7</sup> / <sub>8</sub> ", 1 door
999CABH01078	1000 x 700 x 860mm - 39 <sup>3</sup> / <sub>8</sub> " x 17 <sup>9</sup> / <sub>16</sub> " x 33 <sup>7</sup> / <sub>8</sub> ", 2 doors
999CABH01278	1200 x 700 x 860mm - 47 <sup>1</sup> / <sub>4</sub> " x 17 <sup>9</sup> / <sub>16</sub> " x 33 <sup>7</sup> / <sub>8</sub> ", 2 doors





## Base unit with sliding doors and adjustable shelf

code	description
999CABS01078	1000 x 700 x 860mm - 39 <sup>3</sup> / <sub>8</sub> " x 17 <sup>9</sup> / <sub>16</sub> " x 33 <sup>7</sup> / <sub>8</sub> "
999CABS01278	1200 x 700 x 860mm - 47 <sup>1</sup> / <sub>4</sub> " x 17 <sup>9</sup> / <sub>16</sub> " x 33 <sup>7</sup> / <sub>8</sub> "



## BASE CABINET UNITS FOR SINKS

700mm (27 <sup>5</sup>/<sub>9</sub> inches) depth open, cabinet for sink with sliding doors.  
600mm (23 <sup>5</sup>/<sub>8</sub> inches) depth open available in price list.

### Base unit with 2 sliding doors for sinks

code	description
999CABSS1078	1000 x 700 x 860mm - 39 <sup>3</sup> / <sub>8</sub> " x 17 <sup>9</sup> / <sub>16</sub> " x 33 <sup>7</sup> / <sub>8</sub> "
999CABSS1278	1200 x 700 x 860mm - 47 <sup>1</sup> / <sub>4</sub> " x 17 <sup>9</sup> / <sub>16</sub> " x 33 <sup>7</sup> / <sub>8</sub> "
999CABSS1578	1500 x 700 x 860mm - 59 <sup>1</sup> / <sub>16</sub> " x 17 <sup>9</sup> / <sub>16</sub> " x 33 <sup>7</sup> / <sub>8</sub> "



### Base unit with hinged doors for sinks

code	description
999CABHS1078	1000 x 700 x 860mm - 39 <sup>3</sup> / <sub>8</sub> " x 17 <sup>9</sup> / <sub>16</sub> " x 33 <sup>7</sup> / <sub>8</sub> ", 2 doors
999CABHS1278	1200 x 700 x 860mm - 47 <sup>1</sup> / <sub>4</sub> " x 17 <sup>9</sup> / <sub>16</sub> " x 33 <sup>7</sup> / <sub>8</sub> ", 2 doors
999CABHS1578	1500 x 700 x 860mm - 59 <sup>1</sup> / <sub>16</sub> " x 17 <sup>9</sup> / <sub>16</sub> " x 33 <sup>7</sup> / <sub>8</sub> ", 3 doors



## KICKPLATE

Stainless steel kickplate for enclosing base of cabinets.  
To be ordered according to length of base cabinet and any open ends.

code	description
999CABW08000	Kickplate



## STAINLESS STEEL WORKTOPS

Stainless steel worktops with 100mm - 3<sup>15</sup>/<sub>16</sub>" splash guard available in either 600mm - 23<sup>5</sup>/<sub>8</sub>" or 700mm - 27<sup>9</sup>/<sub>16</sub>" depth to match the depth of base units. Worktops need to be ordered by length, according to the length of base units.  
To ensure access through facility doors, lengths over 3m are not suggested

code	description
999CABW08060	600mm - 23 <sup>5</sup> / <sub>8</sub> " wide sold by metre
999CABW08070	700mm - 17 <sup>9</sup> / <sub>16</sub> " wide sold by metre



## ULTRASOUND INSTALLATION IN BENCHTOP

Ultrasound unit flush mounted installation requires a base cabinet unit for sinks.

code	description
999CABULINST	Installation of US 10, US 18, US 21, US 28 ultrasonic units into worktop (choose ultrasonic unit separately)
999CABULINS1	Installation of US 46 ultrasonic unit into worktop (choose ultrasonic unit separately)

Installation detail on technical specifications



## SINKS

Fully welded AISI 304 stainless steel and seamlessly integrated into worktops, sinks are available in large or small sizes and can be ordered as a single or double configuration for installation on the left, middle or right hand side of worktops into cabinets for sinks underneath.

Sink type	Left	Center	Right
←▲ Small single sink	999CABLSS542	999CABCSS542	999CABRSS542
←↔▼ Small double sink	999CABLSD542	999CABCSD542	999CABRSD542
↔▲ Large single sink	999CABLLS653	999CABCLS653	999CABRLS653
↔↔▲ Large double sink	999CABLLD653	999CABCLD653	999CABRLD653
↔↔↔▶ Large triple sink	999CABLLT653	999CABCLT653	999CABRLT653



- ← small sink dimensions: 500 x 400 x 250h mm - 19 1/16" x 15 3/4" x 9 13/16" h
- ↔ large sink dimensions: 600 x 500 x 300h mm - 23 5/8" x 19 11/16" x 11 13/16" h
- ▲- Min. requirement 1m - 39 3/8" sink base    ▼- Min. requirement 1.2m - 47 1/4" sink base
- ◀- Min. requirement 1.5m - 59 1/16" sink base    ▶- Min. requirement 2 x 1m - 39 3/8" sink bases

## ENDOSCOPY WORKSTATION

To aid ergonomics and achieve high levels of decontamination, manual cleaning endoscope workstations have been designed to avoid having to coil the endoscope up in a sink. Designed to fit Steelco EPW 100 S unit. These units are fitted complete with worktops and hot/cold mixer taps with flexible shower included.

### MANUAL FILLING SINK

dimensions WxDxH mm	stainless steel sink	Corian® sink	fixed height	adjustable height
1200x700x900	9992477	9992447	•	
1600x700x900	9992479	9992467	•	
2000x700x900	9992481	9992469	•	
1200x700x850-1150	9992478	9992448		•
1600x700x850-1150	9992480	9992468		•
2000x700x850-1150	9992482	9992470		•





### AUTOMATIC FILLING SINK

dimensions WxDxH mm	stainless steel sink	Corian® sink	fixed height	adjustable height
1200x700x900	99913220	99912641	•	
1600x700x900	99913129	99912640	•	
2000x700x900	99913223	99912642	•	
1200x700x850-1150	99913221	99912643		•
1600x700x850-1150	99913222	99912644		•
2000x700x850-11510	99913224	99912608		•



### STAINLESS STEEL CABINET

500x700x950 stainless steel cabinet with 1 hinged door



## FAUCET AND ACCESSORIES

If you wish to have sink pre drilled for taps, shower or accessories, please specify exact location.

### Faucet

Mixer tap with manually operated long neck lever control for hot and cold water

999CABTLHC01



### Faucet with shower head

Hot and cold tap with additional shower feature for pre cleaning

999CABTFHC00



### Air/Water spray gun

Can be used with either water or compressed air. Features a lightweight aluminium body, heat insulated handle with trigger pressure controlling airflow or water spray. Not suitable for use with DI water.

999CABTAGN00



### Accessories

8 nozzle accessory set for rinsing, suctioning and drying. Not suitable for use with DI water.

999CABTAGN80



### Hega® stainless steel water/air gun

Hega® stainless steel water /air gun. Recommended if using DI or RO water in sink area.

9992243



### Accessories

Tips for Hega stainless steel water /air gun

9992244



Hega® air/water gun wall support

9992804

## LIQUID SOAP DISPENSER

code	description
999CABSD00000	Liquid soap dispenser



## SPLASH GUARDS FOR SINKS

code	description
9992654	Height adjustable splash guard and support for sink



## SINK DOSING SYSTEM

Flow based sink dosing system designed to deliver a precise volume of detergent eliminating the variability of manually filling. Can be linked into a centralised dosing system to eliminate the need to change detergent bottles. Additional standard features include temperature monitoring to ensure optimal detergent activity as well as a soak timer. Supplied complete with an easy to use installation kit. Options include a foot pedal for touchless operation and low level alarm for the detergent bottle.

code	description
999DOS000001	Flow based sink dosing system with installation kit
999DOS000002	Foot pedal for hands free sink dosing
999DOS000003	Detergent low level alarm



## MANUAL POWER WASH FOR TROLLEYS

For the manual pre-cleaning or cleaning of carts and other furniture. Water pressure driven between 2 to 6 bar up to 50°C/122°F, does not need connection to power or steam supply. Automatic dosing of detergent.

Comes complete with wall mounting kit, cleaning gun, 15m - 49ft length hose and stainless steel 1/2" to 3/4" connection kit.

code	description
999MTPW00000	Manual power wash for trolleys





## WALL MONTED EYE WASH SINK

Wall mounted eyewash sink with stainless steel bowl and intuitive easy to use large activation handle.

code	description
99912316	Wall monted eye wash sink



## TRANSPORT TROLLEY FOR DECONTAMINATION CONTAINERS

Used to transport instruments in sealed containers with liquid from OR to CSSD.

code	description
999MOBSC0005	Transport trolley for decontamination container dim 410 x 690 x 1000 h mm - 16 <sup>1</sup> / <sub>8</sub> " x 27 <sup>3</sup> / <sub>16</sub> " x 39 <sup>3</sup> / <sub>8</sub> "
999MOBSC0008	Plastic container with lid for transportation of contaminated instruments dim 400 x 600 x 230 h mm - 15 <sup>3</sup> / <sub>4</sub> " x 23 <sup>5</sup> / <sub>8</sub> " x 9 <sup>1</sup> / <sub>16</sub> "
9992303	Tap for transportation container



## SUCTION PUMP FOR USE WITH LIQUID CONTAINERS

Foot pedal operated freestanding compact suction pump and aspiration hose with direct connection to drainage system. Of AISI 304 stainless steel construction with TIG welding and a durable pump, shipped complete with foot pedal to ensure hands free operation.

code	description
999MOBSC0006	Suction pump for use with liquid containers
999MOBSC0007	Suction pump integrated under bench



## REFUSE BAG HOLDERS

Single or double free standing refuse bag holders are available as well as single wall mounted unit. For wall and free standing units options are a lid + hinge. Free standing units alternatively can be ordered with a push handle and either a lid + hinge or pedal system and lid. Different color lids are available on demand.

code	description
999RFB000001	Single refuse bag - mobile holder - 360x510x910mm - 14 <sup>3</sup> / <sub>16</sub> "x20 <sup>1</sup> / <sub>16</sub> "x35 <sup>13</sup> / <sub>16</sub> "
999RFB000002	Twin refuse bag - mobile holder - 735x510x910mm - 28 <sup>15</sup> / <sub>16</sub> "x20 <sup>1</sup> / <sub>16</sub> "x35 <sup>13</sup> / <sub>16</sub> "
999RFB000003	Single refuse bag - wall mounted holder 400x300x300 - 15 <sup>3</sup> / <sub>4</sub> "x11 <sup>13</sup> / <sub>16</sub> "x11 <sup>13</sup> / <sub>16</sub> "
999RFB000004	Pedal system (only for mobile holder)
999RFB000005	Handle (only for mobile holder)
999RFB000006	Hinge for lid without pedal
999RFB000007	lid



Single refuse bag



Twin refuse bag



Single refuse bag, wall mounted



Pedal system



Hinge for lid



lid



Handle





## SMALL ULTRASONIC CLEANERS

In addition to the range of larger freestanding ultrasonic units that are highlighted in a separate leaflet, Steelco offers a range of small benchtop and built in ultrasonic units up to 1 DIN basket capacity. Irrespective of which size model is chosen, they all feature impressive performance with features usually associated with larger models.



Steelco models: US 10, US 18, US 21, US 28

## MAIN FEATURES

Depending on model:

- Adjustable degassing time to maximize process efficiency
- Sweep oscillation module to ensure powerful even coverage
- Storage capacity for up to 10 programs
- Waterproof membrane keyboard with LED display and sturdy handles
- Adjustable cleaning time from 0 to 99 minutes
- Temperature setting
- High output piezoelectric transducers
- Easy clean stainless steel body
- Lid and basket included as standard

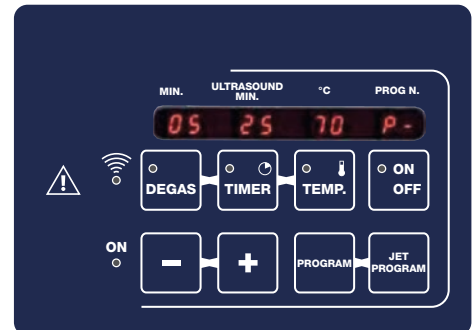

Control panel of Steelco US 10 up to US 28 models



Steelco US 46 model



## SMALL ULTRASONIC CLEANERS

Models and accessories

Model	US 10	US 18	US 21	US 28	US 46
<b>Catalog number:</b> free standing	999US10B0000	999US18B0000	999US21B0000	999US28B0000	-
flush mounted	999US10FM000	999US18FM000	999US21FM000	999US28FM000	999US46FM000
External dimension LxWxH	400x270x370mm 15 <sup>3</sup> / <sub>4</sub> "x10 <sup>5</sup> / <sub>8</sub> "x14 <sup>9</sup> / <sub>16</sub> "	440x340x410mm 17 <sup>5</sup> / <sub>16</sub> "x13 <sup>3</sup> / <sub>8</sub> "x16 <sup>9</sup> / <sub>8</sub> "	600x330x410mm 23 <sup>5</sup> / <sub>8</sub> "x13"x16 <sup>1</sup> / <sub>8</sub> "	600x330x410mm 23 <sup>5</sup> / <sub>8</sub> "x13"x16 <sup>1</sup> / <sub>8</sub> "	660x460x290mm 26"x18 <sup>1</sup> / <sub>8</sub> "x11 <sup>7</sup> / <sub>16</sub> "
Tank dimension LxWxH	300x240x150mm 11 <sup>13</sup> / <sub>16</sub> "x9 <sup>7</sup> / <sub>16</sub> "x5 <sup>15</sup> / <sub>16</sub> "	330x300x200mm 13"x11 <sup>13</sup> / <sub>16</sub> "x7 <sup>7</sup> / <sub>8</sub> "	500x300x150mm 19 <sup>11</sup> / <sub>16</sub> "x11 <sup>13</sup> / <sub>16</sub> "x5 <sup>15</sup> / <sub>16</sub> "	500x300x200mm 19 <sup>11</sup> / <sub>16</sub> "x11 <sup>13</sup> / <sub>16</sub> "x7 <sup>7</sup> / <sub>8</sub> "	600x400x220/260mm 23 <sup>5</sup> / <sub>8</sub> "x15 <sup>3</sup> / <sub>4</sub> "x8 <sup>11</sup> / <sub>16</sub> -10 <sup>1</sup> / <sub>4</sub> "
Capacity	9.5 l - 2.64 gal US	18 l - 4.75 gal US	21 l - 5.55 gal US	28 l - 7.4 gal US	46 l - 12.15 gal US
W peak power	400	600	800	1000	2400
Power connection*	230/240V - 50/60Hz	230/240V - 50/60Hz	230/240V - 50/60Hz	230/240V - 50/60Hz	230/240V - 50/60Hz
Degasing function	•	•	•	•	•
Adjustable cleaning time: 0-90 minutes	•	•	•	•	0 - 30
Heating power	300	500	1000	1000	-
Adjustable cleaning temperature to 70°C/158°F	•	•	•	•	display and alarm
10 program storage capacity with jet function	•	•	•	•	1 program
Adjustable time degas programme	•	•	•	•	automatic
Frequency and sweep system 38kHz to 40kHz	•	•	•	•	•
Lid and basket included	•	•	•	•	◦
<b>Accessories</b>					
Basket catalogue number	999US10BA000	999US18BA000	999US21BA000	999US28BA000	999US46BA000
Optional stainless steel immersion basket (ø71x60mm h - ø2 <sup>3</sup> / <sub>4</sub> "x2 <sup>3</sup> / <sub>8</sub> "h)			999USSSB000		
Basket holder	-	-	-	-	999US46BG000
Hinged lid with gas spring and EPDM gasket	-	-	-	-	999US46HG000
Ultrasound installation**		999CABULINST			999CABULINS1

\* Not available for sale in USA

\*\* Ultrasound unit flush mounted installation requires a base cabinet unit for sinks.

• = Standard ◦ = Option - = Not available



## CLEAN AREA

Following automated cleaning and disinfection, goods are not sterile but are safe to handle and ready to be sorted, inspected and packed. Steelco has a modular approach to designing and building packing workstations around operators according to the tasks they need to perform. This helps to maximize productivity and safety whilst at the same time creating ergonomic solutions and a pleasant work environment.

Furniture in this area is of the highest quality AISI 304 stainless steel and TIG welded for seamless smooth edges that are easy to clean and include:

- Packing tables
- Accessories to configure workstations
- Pouch sealers
- Tables for general use



## PACKING WORKSTATIONS

To ensure the right workstation configuration, it is important to plan the tasks that will be performed and how much countertop space is needed to work effectively and safely. Steelco' factory trained distributors can work with you and also rely on the support of Steelco' layout planning department to configure workstations to best meet your needs.



Low reflection stainless steel top is standard.  
High pressure white core top can be alternatively ordered.





## CUSTOM CONFIGURED WORKSTATIONS

Creating a customized workstation is easy thanks to Steelco's modular approach.

### Step 1 Choose a basic table configuration

For packing workstations, Steelco recommends tables with fixed legs and height adjustable worktops without shelves so that operators can sit or stand comfortably at the optimal ergonomic height. Tables fitted with a shelf are not recommended as they are not compatible with an under counter cupboards, drawers or PC holder.

Tables suitable for workstations are available in length from 1200mm - 47<sup>1</sup>/<sub>4</sub>" to 2200mm - 86<sup>3</sup>/<sub>5</sub>".

description	code	+	dimensional code					
Fixed height table	999TAF00	+	1200	1400	1600	1800	2000	
Electrically height adjustable table	999TAV00	+		1400	1600	1800	2000	2200
Fixed height table <b>with wheels</b>	999TAF0W	+	1200	1400	1600	1800	2000	
Electrically height adjustable table <b>with wheels</b>	999TAV0W	+		1400	1600	1800	2000	2200
Fixed height table <b>with betacryl® top</b>	999TAFNO	+		1400	1600	1800	2000	
Electrically height adjustable table <b>with betacryl® top</b>	999TAVNO	+		1400	1600	1800	2000	2200
Fixed height table <b>with betacryl® top and wheels</b>	999TAFNW	+		1400	1600	1800	2000	
Electrically height adjustable table <b>with betacryl® top and wheels</b>	999TAVNW	+		1400	1600	1800	2000	2200
			47 <sup>1</sup> / <sub>4</sub> "	55 <sup>1</sup> / <sub>8</sub> "	63"	70 <sup>6</sup> / <sub>7</sub> "	78 <sup>3</sup> / <sub>4</sub> "	86 <sup>3</sup> / <sub>5</sub> "

1200 and 1400mm (55<sup>1</sup>/<sub>8</sub>"") can only accept 1 x support for baskets and accessories. 1600mm (63") and above tables can accept 1 or 2

Electrical height position with 4 memory keys 999TAV54M000



### Step 2 Choose supporting structures - Support for baskets and accessories

The **Support for baskets and accessories**, which is attached to the back of the table, supports numerous different shelves, basket and dispenser options. 1200/1400mm tables can have 1 support fitted with either 1 or 2 for tables 1600mm - 63" or longer.

code	description
999TAASU0000	Support for baskets and accessories H=1015mm



999TAADI0005 Support for suspending 1 or 2 baskets on the side of tables

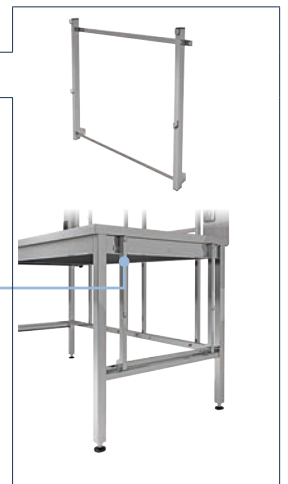
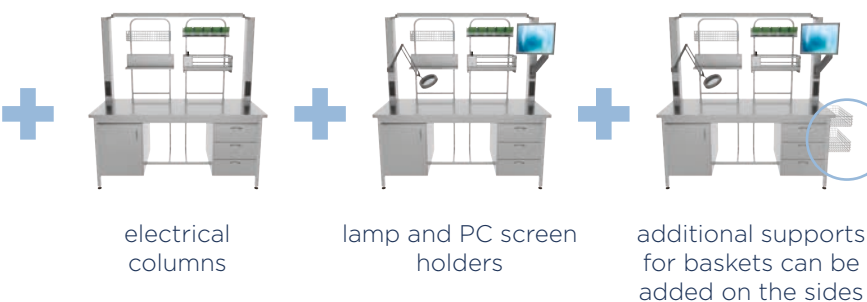

### Step 3 Choose the accessories that you need

Accessories that are suitable for attaching to the support for baskets and accessories 999TAASU0000, can be easily attached on several levels.

code	description
999TAALA0001	Lamp for tables 1200-1400-1600mm (in lieu of electrical columns)
999TAALA0002	Lamp for tables 1800-2000-2200mm 70 <sup>7</sup> / <sub>8</sub> "-78 <sup>3</sup> / <sub>4</sub> "-86 <sup>5</sup> / <sub>8</sub> " (in lieu of electrical columns)



999TAACS0001	Container support with 6 units of 75mm container
999TAACS0002	Container support with 4 units of 120mm container
999TAACS0003	Container support with 3 units of 200mm container



code	description
999TAASH0001	Flat Shelf 630x350mm - 24 <sup>13</sup> / <sub>16</sub> "x 13 <sup>13</sup> / <sub>16</sub> "
999TAASH0003	Flat Shelf 1100mm - 43 <sup>5</sup> / <sub>16</sub> width (requires two supports for baskets and accessories)
999TAASH0004	Flat Shelf 1500mm - 59 <sup>1</sup> / <sub>16</sub> width (requires two supports for baskets and accessories)



999TAADI0055	5 compartment tilt bin dispenser
999TAADI0003	3 tilt bin dispenser

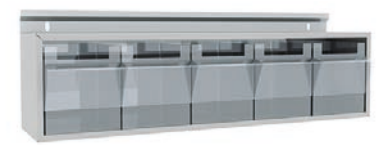

999TAAP00000	Pouch reel cutter size 630mm - 24 <sup>13</sup> / <sub>16</sub>
999TAAP00001	Pouch reel holder



code	description
999TASSB0001	Storage basket high 575x275x260h mm - 22 <sup>5</sup> / <sub>8</sub> "x10 <sup>13</sup> / <sub>16</sub> "x10 <sup>1</sup> / <sub>4</sub> "
999TASSB0002	Storage basket high with window cut out mm 575 x 275 x 260h - 22 <sup>5</sup> / <sub>8</sub> "x10 <sup>13</sup> / <sub>16</sub> "x10 <sup>1</sup> / <sub>4</sub> "
999TASSB0003	Storage basket low mm 575 x 275 x 130h - 22 <sup>5</sup> / <sub>8</sub> "x10 <sup>13</sup> / <sub>16</sub> "x5 <sup>1</sup> / <sub>8</sub> "
999TASSB0004	Pair of inclined support for baskets





## Step 4 Choose supporting structures - Electrical columns for tables

If overhead operator lighting, sockets, on /off switches are needed, the relevant pair of electrical columns based on the length of table top is selected. These also support the optional PC screen arm holder or magnifying lamp.

code	description
999TAAEL1400	1 Pair of electrical columns for table 1400mm - 55 <sup>1</sup> / <sub>8</sub> " long
999TAAEL1600	1 Pair of electrical columns for table 1600mm - 63" long
999TAAEL1800	1 Pair of electrical columns for table 1800mm - 70 <sup>7</sup> / <sub>8</sub> " long
999TAAEL2000	1 Pair of electrical columns for table 2000mm - 78 <sup>3</sup> / <sub>4</sub> " long
999TAAEL2200	1 Pair of electrical columns for table 2200mm - 86 <sup>5</sup> / <sub>8</sub> " long

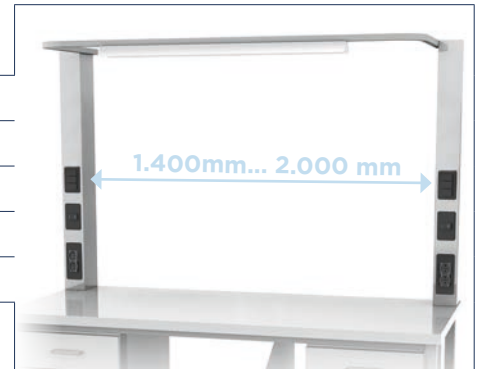



Electrical columns standard equipment is: 4 electrical sockets (Schuko type), 3 on/off switches (for: general, overhead light, magnifier light), overhead 2000 lumen light, supports for optional magnifying lamp or PC monitor holder. Additional electrical sockets, on off switches, RJ 45 network sockets etc. Can be ordered according to customer needs. *Not available for sale in USA.*

code	description
999TAALA0000	Examination lamp with x 5 magnification led (suitable for connection to electrical columns and table top)
999TAASUPC00	PC Screen arm holder up to 9 Kg. (for connection to electrical columns)



## Step 5 Choose under worktop storage option

Select drawer units, cupboard or PC tower holder as needed

code	description		
999TAADR0001	1 drawer unit 150mm - 5 <sup>7</sup> / <sub>8</sub> " high		
999TAADR0002	2 drawer unit 150mm - 5 <sup>7</sup> / <sub>8</sub> " high each, total 300mm - 11 <sup>13</sup> / <sub>16</sub> "		
999TAADR0003	3 drawer unit 150mm - 5 <sup>7</sup> / <sub>8</sub> " high each, total 450 mm 17 <sup>11</sup> / <sub>16</sub> "		
999TAADR0004	Lock and key for a single drawer		
999TAADR0005	PC holder		
999TAADR0007	Printer holder		
999TAADR0006	Cabinet LxWxH 450x600x630mm - 17 <sup>3</sup> / <sub>4</sub> "x23 <sup>5</sup> / <sub>8</sub> "x24 <sup>13</sup> / <sub>16</sub> "		

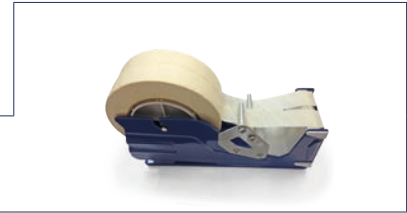

code	description
9992091	Double tape dispenser, two rolls up to 25mm/1" wide or one up to 50mm/2" wide

## STOOLS

Stool frames are made of AISI 304 stainless steel with a 5 spoke aluminium base mounted on 60mm antistatic castors with gas raising height adjustment between 550mm and 800mm. Available with comfortable padded standard or saddle seats. Available options include backrest, footrest and footbrake.

code	stools description
999STGPS0000	Stool with gas raising height adjustment and padded seat
999STGPD0000	Stool with gas raising height adjustment and padded saddle



code	stools accessories description
999ST0000001	Backrest
999ST0000003	Adjustable armrest
999ST0000004	Adjustable footrest
999ST0000005	Pedal brake



## ACCESSORIES FOR WRAPS AND LINENS

### Mobile trolley with bottom shelf for storing 4 types of wraps

999MOBWRAP04 Made of AISI 304 tubular stainless steel with large diameter castors with brakes for ease of movement and stability. Bottom shelf prevents any loose sheets falling onto the floor.  
 1360mm x 720mm x 1030mm  
 53<sup>9</sup>/<sub>16</sub>"-28<sup>3</sup>/<sub>8</sub>"-40<sup>9</sup>/<sub>16</sub>"



### Linen inspection window with LED lightbox

9992408 Linen inspection window with LED lightbox. Chose separate packing table extra.



## STAINLESS STEEL WORKTABLES

Made of high quality AISI 304 stainless steel, Steelco's CSSD worktables for wet or dry goods are robust and ideal for heavy-duty areas.

Reinforced frames ensure stability and durability with components TIG welded for joint free smooth surfaces to aid cleaning and maintain hygiene.





Available in lengths from 1200mm - 47<sup>1</sup>/<sub>4</sub>" to 2200mm - 86<sup>5</sup>/<sub>8</sub>", tables are 800mm - 31<sup>1</sup>/<sub>2</sub>" wide, supplied either with fixed feet or with 360° rotating 125mm - 4<sup>15</sup>/<sub>16</sub>" easy glide antistatic castors with brakes on 2 wheels.

To ensure optimal working ergonomics, tables are available either as fixed height or with manual or electrical adjustment with options of an integrated fixed or variable height shelf for storage purposes.

code	+ dimensional code	standard	with wheels	electrical adjustable height
999TAF00	+ 1200 1400 1600 1800 2000	•		
999TAF0W	+ 1200 1400 1600 1800 2000	•	•	
999TAV00	+ 1400 1600 1800 2000 2200			•
999TAV0W	+ 1400 1600 1800 2000 2200		•	•
	47 <sup>1</sup> / <sub>4</sub> " 55 <sup>5</sup> / <sub>8</sub> " 63" 70 <sup>7</sup> / <sub>8</sub> " 78 <sup>3</sup> / <sub>4</sub> " 86 <sup>5</sup> / <sub>8</sub> "			

Height adjustable from 850 to 1150 mm

■ = suitable for packing tables

999TAASH0014	Stainless steel shelf for 1400-1600mm - 55 <sup>1</sup> / <sub>8</sub> "-63" tables (requires pair of supports for under table shelf)	
999TAASH0018	Stainless steel shelf for 1800-2000-2200mm - 70 <sup>7</sup> / <sub>8</sub> "-78 <sup>3</sup> / <sub>4</sub> "-86 <sup>5</sup> / <sub>8</sub> " tables (requires pair of supports for under table shelf)	
999TAV54M000	Electrical height position with 4 memory keys	



## STEELCO PS POUCH SEALER RANGE

The Steelco range of rotary pouch sealers and accessories ensure the aseptic integrity of single use sealable pouches including Tyvek® by consistently providing a perfect seal. Models feature validatable processes according to ISO 11607-2 and guidance document ISO/TS 16775 with the monitoring of temperature, contact pressure and sealing speed dependent on model to provide the optimum seal that is strong enough yet easy to peel.

Steelco sealers are made of robust stainless steel with flat surfaces for ease of cleaning and feature energy saving functions including automatic standby function. Versions are available with integrated printers that adjust the font size to the pouch width. Several models can be linked to instrument tracking systems and printers.



### PS 400 POUCH SEALER

cod. 99912150



The most advanced pouch sealer available.

- ✓ **Low energy consumption**
- ✓ **Intuitive 4.3" crystal clear touch screen display**
- ✓ **Advanced connectivity.** Communication, programming and repeating function and **integrated printer** with automatic font size adjustment.



**Easy to use display**



**Wide range of connectivity options**

### PS 300 POUCH SEALER

cod. 99911311



- ✓ **Integrated printer** with automatic font size adjustment.
- ✓ **Adjustable sealing temperature, speed** (up to 13 m per minute) and **pressure** with unit counter.
- ✓ **Automatic standby** and fast start up function to minimize energy use but maximize output.



Programmable and operated through colour touch screen panel or via a barcode scanner or external computer.



RS232, USB and Ethernet connection as standard.



## PS 200 POUCH SEALER

Check price list code for correct electrical voltage.



- ☑ **Integrated printer** with automatic font size adjustment.
- ☑ Programmable and operated **via touch keys** or via a barcode scanner or external computer. RS232 connection.
- ☑ Sealing **temperature, speed** and **pressure** monitoring according to ISO 11607-2.
- ☑ Automatic **standby** and **fast start up function** to minimize energy use.

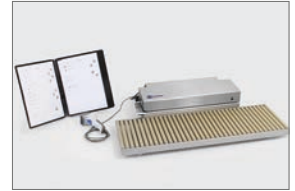

## PS 100 POUCH SEALER

Check price list code for correct electrical voltage.



- ☑ Programmable and operated **via touch keys**.
- ☑ **Sealing temperature and pressure** monitoring according to ISO 11607-2.
- ☑ Automatic **standby** and **fast start up function** to minimize energy use but maximize output.



## ACCESSORIES

Accessories include single and twin level cutting devices, roller conveyor or tray that can be integrated into workstations to provide optimal workflow efficiency and user ergonomics.

### PS Pouch seal cutter

For the storage and cutting of different size pouch reels.

cod. 99911314

2nd level reel storage available as option.

cod. 99911322

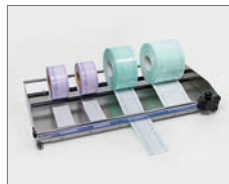

### PS barcode scanner and software

Can operate PS 400, PS 300 and PS 200 sealers, with automatic assignment to the appropriate device function using barcode lists reading the custom specific packaging information.

cod. 99911313



### PS roller conveyor

Compatible with all Steelco PS pouch sealers.

W x D x H:

830 x 280 x 60mm

cod. 99911312

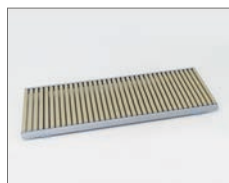

### PS barcode printer

Prints labels with batch identification, sterilisation date, type, expiration.

cod. 99911321 Label printer for PS 400

cod. 99912565 Label printer for PS 300

cod. 99912566

Labels 49x38mm 1050 pcs

cod. 99912567

Labels 105x149mm 275 pcs



### PS tray

Compatible with all Steelco PS pouch sealers.

W x D x H:

850 x 280 x 60mm

cod. 99911310



## STEELCO PS POUCH SEALER RANGE SPECIFICATIONS

FEATURES	PS 400	PS 300	PS 200	PS 100
<b>Sealing properties</b>				
Sealing distance from edge	0-35 mm	0-35 mm	0-35 mm	0-35 mm
Seal width (up to 19mm on request)	12 mm	12 mm	12 mm	12 mm
Sealing speed	5-13m per min	5-13m per min	10m per min	10m per min
Distance to edge of instrument in pouch	> 30 mm	> 30 mm	> 30 mm	> 30 mm
Power	120 W	400 W	390 W	390 W
Sealable pouches and reels	•	•	•	•
Tyvek®, non woven, SMS and other EN ISO 11607-1 approved	•	•	•	•
Reverse feed	•	•	•	•
Sealing temperature	max 220°C/428°F	max 220°C/428°F	max 220°C/428°F	max 220°C/428°F
2°C temperature regulation tolerance with overheat protection	•	•	•	•
Contact pressure	100 N	70-130 N	100 N	100 N
Piece counter	•	•	•	•
Printing	•	•	•	•
Packaging time + date, expiry, batch, operator and device	•	•	•	•
Automatic font size adjustment according to pouch size	•	•	•	•
Print image rotation and print barcode	•	•	•	•
Print out of sealing test parameters	•	•	•	•
<b>Communications</b>				
RS 232	•	•	•	•
USB	x2	•	◦	•
Ethernet	•	•	•	•
PC configurable with PC back up function	•	•	•	•
External label printer connection	•	•	•	•
Compatible with SteelcoData traceability system	•	•	•	•
Barcode scanner compatible	•	•	•	•
<b>Standards and power supply</b>				
Warranty	2 years	2 years	2 years	2 years
Compliance to ISO 11607-2, DIN 58953-7	•	•	•	•
Validatable process in accordance with ISO 11607-2	•	•	•	•
Monitor sealing temperature, contact pressure, speed	•	•	•	(only temperature and pressure)
Standby energy efficiency mode & autostart	•	•	•	•
Mains Voltage	100-240 V	100-240 V	110/115/230 V	110/115/230 V
Mains frequency	50/60 hz	50/60 hz	50/60 hz	50/60 hz
Settings recall and date readjust after power failure	•	•	•	•
Weight	15.5Kg	21Kg	15Kg	12Kg
Dimensions width x depth x height (mm/inches)	560 x 255 x 145 22 <sup>1</sup> / <sub>16</sub> x 10 <sup>1</sup> / <sub>16</sub> x 5 <sup>11</sup> / <sub>16</sub>	710 x 260 x 240 27 <sup>15</sup> / <sub>16</sub> x 10 <sup>1</sup> / <sub>4</sub> x 9 <sup>7</sup> / <sub>16</sub>	560 x 255 x 145 22 <sup>1</sup> / <sub>16</sub> x 10 <sup>1</sup> / <sub>16</sub> x 5 <sup>11</sup> / <sub>16</sub>	510 x 255 x 145 20 <sup>1</sup> / <sub>16</sub> x 10 <sup>1</sup> / <sub>16</sub> x 5 <sup>11</sup> / <sub>16</sub>

• = Standard    ◦ = Optional

Tyvek® is a reg. Trademark of E.I. du Pont de Nemours



## STERILE AREA - Storage and transportation solutions

Once goods have been sterilized, they are in the sterile zone and either transported immediately to their point of use or stored ready for transfer. Steelco has a number of different storage, transfer and transport solutions for DIN and ISO size containers as well as wrapped goods and pouches.

Shelving is available in both stainless steel and aluminium structures with solid or wire shelves or runners for baskets.

Pass through cabinet effectively separates the sterile area from the outside and enables the loading of containers and wraps into trolleys either from inside of the sterile area or from the outside.

Steelco's wide range of options enables you to make the best use of available space:

- Mobile open storage and transportation
- Closed instrument carts
- Shelving systems
- Filing and pass through cabinets



## MOBILE OPEN STORAGE AND TRANSPORTATION

A wide range of different open mobile transport solutions meet the distribution needs of DIN and ISO basket or container systems and pouches with products available for internal storage and transportation within CSSDs or to their point of use.

Mobile open storage and transport systems are TIG welded, made of AISI 304 stainless steel and fitted with 2 fixed and 2 swivel antistatic wheels, with brakes to aid manoeuvrability and reduce floor wheel marks.

Steelco's mobile storage transport systems can if required be cleaned and disinfected in cart washers.

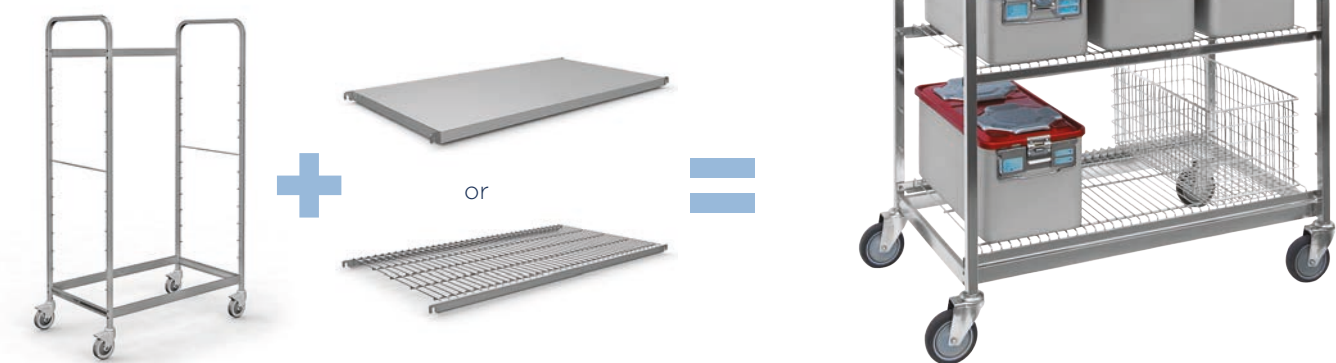

### Mobile trolleys with shelves for baskets or containers

Available in 1000, 1200, 1400mm -  $39\frac{3}{8}$ "",  $47\frac{1}{4}$ "",  $55\frac{1}{8}$ " lengths these mobile shelf trolleys hold either solid or wire shelves that are adjustable every 110mm-  $4\frac{5}{16}$ ". Mostly used within CSSDs.

code	description	dimension L x W x H
999MOBNST000	<b>Narrow</b> shelf trolley	600 x 600 x 1800mm - $23\frac{5}{8}$ " x $23\frac{5}{8}$ " x $70\frac{7}{8}$ "
999MOBNSSS00	Stainless steel solid shelf	600 x 540 - $23\frac{5}{8}$ " x $21\frac{1}{4}$ "
999MOBNSWS00	Stainless steel wire shelf	600 x 540 - $23\frac{5}{8}$ " x $21\frac{1}{4}$ "
999MOBCST000	<b>Compact</b> shelf trolley	1000 x 600 x 1800mm - $39\frac{3}{8}$ " x $23\frac{5}{8}$ " x $70\frac{7}{8}$ "
999MOBCSSS00	Stainless steel solid shelf	965 x 540 - 38" x $21\frac{1}{4}$ "
999MOBCSWS00	Stainless steel wire shelf	1000 x 540 - $39\frac{3}{8}$ " x $21\frac{1}{4}$ "
999MOBMST000	<b>Medium</b> shelf trolley	1200 x 600 x 1800 - $47\frac{1}{4}$ " x $23\frac{5}{8}$ " x $70\frac{7}{8}$ "
999MOBMSSS00	Stainless steel solid shelf	1165 x 540 - $45\frac{7}{8}$ " x $21\frac{1}{4}$ "
999MOBMSSWS00	Stainless steel wire shelf	1200 x 540 - $47\frac{1}{4}$ " x $21\frac{1}{4}$ "
999MOBLST000	<b>Large</b> shelf trolley	1400 x 600 x 1800 - $55\frac{1}{8}$ " x $23\frac{5}{8}$ " x $70\frac{7}{8}$ "
999MOBLSSS00	Stainless steel solid shelf	1350 x 540 - $53\frac{1}{8}$ " x $21\frac{1}{4}$ "
999MOBLSWS00	Stainless steel wire shelf	1400 x 540 - $55\frac{1}{8}$ " x $21\frac{1}{4}$ "



## Mobile distribution trolley for 10 SPRI baskets

Holds up to 10 baskets with a solid bottom shelf.  
Suitable for distribution of goods between CSSD and OR or wards.

code	description	dimension L x W x H
999MOB10SPRI	Mobile Distribution trolley for up to 10 SPRI baskets	650 x 450 x 1925mm 25 <sup>19</sup> / <sub>32</sub> " x 17 <sup>23</sup> / <sub>32</sub> " x 75 <sup>25</sup> / <sub>32</sub> "

See page 48 for suitable SPRI baskets and shelves

Covers available as option on request.



## Mobile trolley for containers

Designed for the distribution of either 3, 6 or 9 DIN and either 3 or 6 ISO containers depending on model.

code	description	dimension L x W x H
999MOBSWISOC	Single width trolley with adjustable guides - ISO containers	600 x 453 x 1620h mm 23 <sup>5</sup> / <sub>8</sub> " x 17 <sup>13</sup> / <sub>16</sub> " x 63 <sup>25</sup> / <sub>32</sub> "
999MOBDWISOC	Double width trolley with adjustable guides - ISO containers	600 x 881 x 1620h mm 23 <sup>5</sup> / <sub>8</sub> " x 34 <sup>11</sup> / <sub>16</sub> " x 63 <sup>25</sup> / <sub>32</sub> "
999MOBSWDINC	Single width trolley with adjustable guides - DIN containers	600 x 356 x 1275h mm 23 <sup>5</sup> / <sub>8</sub> " x 14" x 50 <sup>3</sup> / <sub>16</sub> "
999MOBDWDINC	Double width trolley with adjustable guides - DIN containers	600 x 687 x 1275h mm 23 <sup>5</sup> / <sub>8</sub> " x 27 <sup>1</sup> / <sub>16</sub> " x 50 <sup>3</sup> / <sub>16</sub> "
999MOBTWDINC	Triple width trolley with adjustable guides - DIN containers	600 x 1018 x 1275h mm 23 <sup>5</sup> / <sub>8</sub> " x 40 <sup>1</sup> / <sub>16</sub> " x 50 <sup>3</sup> / <sub>16</sub> "



## Service carts

Commonly used in the CSSD for temporary storage of items next to workstations. Available with either 2 or 3 shelves with retaining guards or edges and in 2 different sizes

code	description	dimension L x W x H
999MOBSC0001	Service cart with 2 shelves with retaining edges	960 x 660 x 950h mm 37 <sup>13</sup> / <sub>16</sub> " x 26" x 37 <sup>3</sup> / <sub>8</sub> "
999MOBSC0002	Service cart with 3 shelves with retaining edges	960 x 660 x 950h mm 37 <sup>13</sup> / <sub>16</sub> " x 26" x 37 <sup>3</sup> / <sub>8</sub> "



## MOBILE AND WALL MOUNTED BASKET SYSTEM

These flexible systems can accommodate both baskets and a number of accessories designed to hold different commonly used items.

Different length wall brackets are available between 940mm - 37" and 1660mm 65<sup>3</sup>/<sub>8</sub>" with 3 to 6 levels of basket holding pins at 220mm - 7<sup>7</sup>/<sub>8</sub>", 320mm - 12<sup>5</sup>/<sub>8</sub>" or 400mm - 15<sup>3</sup>/<sub>4</sub>" separation depending on model 3 different sized trolleys are available for holding either 3, 6 or 8 baskets.

code	description	dimension L x W x H
999MOBT84000	Trolley for transporting up to 8 baskets with 4 per side	555 x 630 x 1620 mm 21 <sup>7</sup> / <sub>8</sub> " x 24 <sup>13</sup> / <sub>16</sub> " x 63 <sup>13</sup> / <sub>16</sub> "

See page 21 for basket options

for up to 8 baskets on 2 sides



### Wall mounting brackets

code	description	height
999MOBWB4134	Pair of wall mounting rail brackets with 4 pins each	883mm - 34 <sup>3</sup> / <sub>4</sub> "





## Accessories for trolleys and wall mounted brackets

code	description		
999TAASH0001	Flat Shelf 630x350mm - 24 <sup>13</sup> / <sub>16</sub> " x 13 <sup>13</sup> / <sub>16</sub> "		
999TAASH0003	Flat Shelf 1100x350mm - 43 <sup>5</sup> / <sub>16</sub> " x 13 <sup>13</sup> / <sub>16</sub> "		
999TAASH0004	Flat Shelf 1500x350mm - 59 <sup>1</sup> / <sub>16</sub> " x 13 <sup>13</sup> / <sub>16</sub> "		
999TAADI0055	5 compartment tilt bin dispenser		
999TAADI0003	3 compartment tilt bin dispenser		
999MOBUBH000	Urine bottle holder - 6 bottles		
999MOBSH0000	OR shoe holder - 6 pairs		

## Stainless steel footwear changing bench

code	description	
999FCB000000	1000 x 450 x 500h mm - 39 <sup>3</sup> / <sub>8</sub> " x 17 <sup>3</sup> / <sub>4</sub> " x 19 <sup>11</sup> / <sub>16</sub> "	

## CLOSED INSTRUMENT CARTS

Sterile instrument transported between the CSSD and the OR need to be protected to ensure that they do not become contaminated or contaminate areas that they pass through.

Steelco has a comprehensive range of closed instrument carts made of stainless steel or light aluminium for the transportation of both DIN and ISO containers and baskets. Models are available with both shelves and guides. All models can be fitted with a range of complementary accessories.



## FULL RANGE OF CLOSED INSTRUMENT CARTS FOR DIN AND ISO CONTAINERS AND BASKETS

Configuration	Fully welded stainless steel	Welded stainless steel	Aluminium light alloy system
6 DIN shelf	•	•	•
9 DIN shelf	•	•	•
6 ISO shelf	•	•	•
Single column DIN runners			
Double column DIN runners	•		•
Three column DIN runners	•		•
Single column ISO runners			•
Double column ISO runners	•		•
Three column ISO runners			•
<b>Features</b>			
Transfer system			
Low profile hinges and gasket system	•	•	•
TIG welded 304 Stainless Steel	•	•	
100% joint free	•		
Joint free in critical areas		•	•
Rubber or PEHD bottom bumper	•	•	•
Push handle	•	•	•
Top bumper	•	o	o
Door opening	255° stop and 270°	270°	270° 255° stop in option
Anti marking wheels	•	•	•
Cleaning detergent type to be used	Alkaline and neutral	Alkaline and neutral	Aluminium safe
AGV and automation compatible	•	•	•
<b>Accessories</b>			
Draw bar	o	o	o
Central brake	o	o	o
Card Holder	o	o	o
Upper bumper	•	•	o
Directional block	o	o	o
Lock	o	o	o
Lock Safety device for seal system	o	o	o

• = Standard    o = Option    - = Not available



## CLOSED INSTRUMENT TROLLEY - FULLY WELDED STAINLESS STEEL

Made of AISI 304 stainless steel with an anti-torsion chassis, all joints are TIG robot welded to ensure smooth surfaces. A ribbed roof for water drainage and reinforced double sheet doors with an interchangeable silicone rubber seal provide an effective barrier against contamination. Anti marking 160mm - 6<sup>5</sup>/<sub>16</sub>" rubber wheels with 2 swivelling and fixed wheels with brakes ensure ease of manoeuvrability.

	Nr. of Containers	Columns with adjustable runners	Columns with fixed runners	Interior with nr. 3 stainless steel shelves
<b>DIN std.</b>	6	999EFW62ADIN 1010 x 710 x 1470mm 39 <sup>5</sup> / <sub>4</sub> " x 27 <sup>15</sup> / <sub>16</sub> " x 57 <sup>7</sup> / <sub>8</sub> "	999EFW62FDIN 1010 x 710 x 1470mm 39 <sup>5</sup> / <sub>4</sub> " x 27 <sup>15</sup> / <sub>16</sub> " x 57 <sup>7</sup> / <sub>8</sub> "	999EFW2S6STU 1010 x 730 x 1470mm 39 <sup>5</sup> / <sub>4</sub> " x 28 <sup>3</sup> / <sub>4</sub> " x 57 <sup>7</sup> / <sub>8</sub> "
	9	999EFW93ADIN 1260 x 710 x 1470mm 49 <sup>5</sup> / <sub>8</sub> " x 28 <sup>3</sup> / <sub>4</sub> " x 57 <sup>7</sup> / <sub>8</sub> "	999EFW93FDIN 1260 x 710 x 1470mm 49 <sup>5</sup> / <sub>8</sub> " x 27 <sup>15</sup> / <sub>16</sub> " x 57 <sup>7</sup> / <sub>8</sub> "	999EFW2S9STU 1260 x 730 x 1470mm 49 <sup>5</sup> / <sub>8</sub> " x 28 <sup>3</sup> / <sub>4</sub> " x 57 <sup>7</sup> / <sub>8</sub> "
<b>ISO std.</b>	6	999EFW62AISO 1260 x 710 x 1470mm 49 <sup>5</sup> / <sub>8</sub> " x 28 <sup>3</sup> / <sub>4</sub> " x 57 <sup>7</sup> / <sub>8</sub> "	999EFW62FISO 1260 x 710 x 1470mm 49 <sup>5</sup> / <sub>8</sub> " x 27 <sup>15</sup> / <sub>16</sub> " x 57 <sup>7</sup> / <sub>8</sub> "	999EFW2S9STU 1260 x 730 x 1470mm 49 <sup>5</sup> / <sub>8</sub> " x 28 <sup>3</sup> / <sub>4</sub> " x 57 <sup>7</sup> / <sub>8</sub> "





### Accessories for STS sterile transfer system and fully welded stainless steel closed instrument trolleys

code	description
999EFWADB000	Draw bar
999EFWACB000	Central brake on 2 wheels
999EFWACC000	Card holder A4
999EFWADB200	Directional block of 2 wheels
999EFWACL000	Cylinder lock with 2 keys
999EFWASD000	Safety device for seal system
999EFWASC000	Round indicator with 3 colors identification of sterility



## CLOSED INSTRUMENT TROLLEY - WELDED STAINLESS STEEL

These trolleys are made of AISI 304 stainless steel with an anti-torsion chassis. Critical joints are TIG welded to ensure smooth surfaces with non-critical areas riveted. Ribbed roof for water drainage and reinforced double sheet doors with interchangeable silicone rubber seal to provide an effective barrier against contamination.

	Nr. of Containers	<b>TALL:</b> interior with nr. 3 loading levels, nr. 2 stainless steel wire shelves	<b>SHORT:</b> interior with nr. 2 loading levels, nr. 1 stainless steel wire shelves
<b>DIN std.</b>	6	999EHW2S1DT0 965 x 750 x 1470mm - 38" x 29 1/2" x 57 7/8"	999EHW1S2DT0 1240 x 770 x 1000mm - 48 3/16" x 30 5/16" x 39 3/8"
	9	999EHW2S2DT0 1185 x 750 x 1470mm - 46 5/8" x 29 1/2" x 57 7/8"	
<b>ISO std.</b>	2		999EHW1S1DT0 840 x 770 x 1000mm - 33 1/16" x 30 5/16" x 39 3/8"
	3	999EHW2S1DT1 785 x 750 x 1470mm - 30 7/8" x 29 1/2" x 57 7/8"	
	4		999EHW1S2DT0 1240 x 770 x 1000mm - 48 3/16" x 30 5/16" x 39 3/8"
	6	999EHW2S2DT0 1185 x 750 x 1470mm - 46 5/8" x 29 1/2" x 57 7/8"	



### Accessories for welded stainless steel closed instrument trolleys

code	description
99904SC2DL2B	Directional block of 2 wheels
9990000LBIDP	Laser barcode ID plate
999EFWACC000	Card holder A4
99900000PDTC	Paper document clamp
999EFWACL000	Cylinder lock with 2 keys
999EFWASC000	Round indicator with 3 colors identification of sterility



### Additional shelves

code	description	
999EHWWS0078	Additional stainless steel wire shelf for 785 & 840 mm width cart	623 x 650 mm
999EHWSS0078	Additional stainless steel solid shelf for 785 & 840 mm width cart	623 x 650 mm
999EHWPWS078	Additional pull-out stainless steel wire shelf for 785 & 840 mm width cart	623 x 650 mm
999EHWWS0118	Additional stainless steel wire shelf for 1185 & 1240 mm width cart	1023 x 650 mm
999EHWSS0118	Additional stainless steel solid shelf for 1185 & 1240 mm width cart	1023 x 650 mm
999EHWPWS118	Additional pull-out stainless steel wire shelf for 1185 & 1240 mm width cart	1023 x 650 mm



## CLOSED INSTRUMENT TROLLEY - ALUMINIUM LIGHT ALLOY

Of lightweight aluminium construction, and featuring a patented closing system with gaskets integrated into doors that can open 270° wide. Units are available with shelves or runners for DIN or ISO systems with a full range of complementary accessories. Models with guides have runners every 114mm - 4½" and are suitable for baskets. As with all aluminium products, it is recommended to clean these transport trolleys with neutral or aluminium safe detergents.

	Nr. of Containers	With nr. 10 pair runners per column	With nr. 3 stainless steel shelves
<b>DIN std.</b>	6	999ELAG6DINO 860 x 710 x 1500mm 33 <sup>7</sup> / <sub>8</sub> " x 27 <sup>15</sup> / <sub>16</sub> " x 59 <sup>1</sup> / <sub>16</sub> "	999ELAS6DINO 860 x 710 x 1500mm 33 <sup>7</sup> / <sub>8</sub> " x 27 <sup>15</sup> / <sub>16</sub> " x 59 <sup>1</sup> / <sub>16</sub> "
	9	999ELAG9DINO 1230 x 710 x 1500mm 48 <sup>7</sup> / <sub>16</sub> " x 27 <sup>15</sup> / <sub>16</sub> " x 59 <sup>1</sup> / <sub>16</sub> "	999ELAS9DINO 1230 x 710 x 1500mm 48 <sup>7</sup> / <sub>16</sub> " x 27 <sup>15</sup> / <sub>16</sub> " x 59 <sup>1</sup> / <sub>16</sub> "
<b>ISO std.</b>	3	999ELAG10ISO 520 x 710 x 1500mm 20 <sup>1</sup> / <sub>2</sub> " x 27 <sup>15</sup> / <sub>16</sub> " x 59 <sup>1</sup> / <sub>16</sub> "	
	6	999ELAG18ISO 1000 x 710 x 1500mm 39 <sup>3</sup> / <sub>8</sub> " x 27 <sup>15</sup> / <sub>16</sub> " x 59 <sup>1</sup> / <sub>16</sub> "	999ELAS9DINO 1230 x 710 x 1500mm 48 <sup>7</sup> / <sub>16</sub> " x 27 <sup>15</sup> / <sub>16</sub> " x 59 <sup>1</sup> / <sub>16</sub> "
	9	999ELAG27ISO 1430 x 710 x 1500mm 56 <sup>5</sup> / <sub>16</sub> " x 27 <sup>15</sup> / <sub>16</sub> " x 59 <sup>1</sup> / <sub>16</sub> "	



### Closed instrument trolley - Aluminium light alloy - accessories

code	description
999ELAACH400	Card holder A4
999ELAACH500	Card holder A5
999ELAADB000	Draw bar
999ELAACB000	Central brake on 2 wheels
999ELAACL000	Cylinder lock with 2 keys
999ELAADB200	Directional block of 2 wheels
999ELAAPV000	Vertical pivot or sloping shelves
999ELAAPB000	Pedal brake on a single castor
999EFWASW000	Stainless steel wheels and chassis
999EFWASC000	Round indicator with 3 colors identification of sterility



## STAINLESS STEEL SHELVING

Entirely made of AISI 304 stainless steel with all joints TIG welded. Of modular design, with up to 1200kg load capacity, easy to assemble without the use of special tools, end sections are electro polished. Can accommodate DIN or ISO containers or basket systems. Available with adjustable solid shelves or with wire shelves or guides.



- If shelving units share common posts, it is recommended to use a cross brace every 2<sup>nd</sup> unit.
- When using ISO or DIN basket guides, use appropriate Z shape brace per unit.

code	description
999SSP060180	Stainless steel post frame with pins 600x1800h mm 23 <sup>5</sup> / <sub>8</sub> " x 70 <sup>7</sup> / <sub>8</sub> "
999SSP060200	Stainless steel post frame with pins 600x2000h m 23 <sup>5</sup> / <sub>8</sub> " x 78 <sup>3</sup> / <sub>8</sub> "
999SSSS10054	Stainless steel solid shelf 1000x540 w mm - 39 <sup>3</sup> / <sub>8</sub> " x 21 <sup>1</sup> / <sub>4</sub> "
999SSSS12054	Stainless steel solid shelf 1200x540 w mm - 47 <sup>1</sup> / <sub>4</sub> " x 21 <sup>1</sup> / <sub>4</sub> "
999SSSS14054	Stainless steel solid shelf 1400x540 w mm - 55 <sup>1</sup> / <sub>8</sub> " x 21 <sup>1</sup> / <sub>4</sub> "
999SSWS10054	Stainless steel wire shelf 1000x540 w mm - 39 <sup>3</sup> / <sub>8</sub> " x 21 <sup>1</sup> / <sub>4</sub> "
999SSWS12054	Stainless steel wire shelf 1200x540 w mm - 47 <sup>1</sup> / <sub>4</sub> " x 21 <sup>1</sup> / <sub>4</sub> "
999SSWS14054	Stainless steel wire shelf 1400x540 w mm - 55 <sup>1</sup> / <sub>8</sub> " x 21 <sup>1</sup> / <sub>4</sub> "
999SSCBR1000	Reinforcement cross brace for 1000mm - 39 <sup>3</sup> / <sub>8</sub> " shelving
999SSCBR1200	Reinforcement cross brace for 1200mm - 47 <sup>1</sup> / <sub>4</sub> " shelving
999SSCBR1400	Reinforcement cross brace for 1400mm - 55 <sup>1</sup> / <sub>8</sub> " shelving

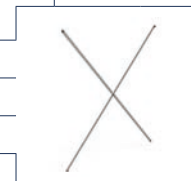
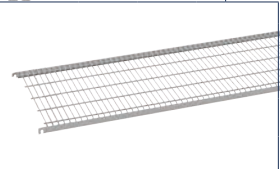
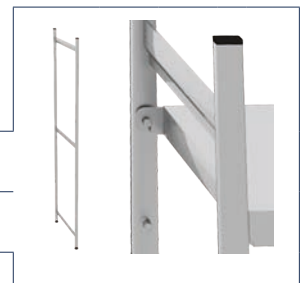



## Assembling examples

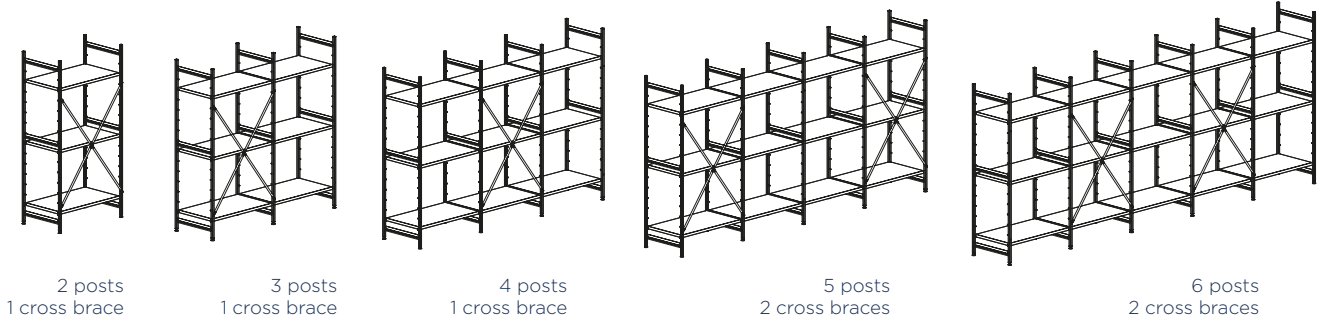

2 posts  
1 cross brace

3 posts  
1 cross brace

4 posts  
1 cross brace

5 posts  
2 cross braces

6 posts  
2 cross braces

code	description	
999SSGIS0B00	Pair of guides for ISO baskets 600 L	
999SSZSP0400	Z shape brace for ISO system	
999SSGDINB00	Pair of guides for DIN baskets 600 L	
999SSZSP0300	Z shape brace for DIN system	
999SSWS03060	Pull out s. steel wire shelf 600x310 w mm 23 <sup>5</sup> / <sub>8</sub> " x 12 <sup>3</sup> / <sub>16</sub> "	
999SSWSRN000	Pair of runners for pull out stainless steel wire shelf	



## HDS - HIGH DENSITY STORAGE SHELVING SYSTEM - TOP GUIDED

High density stainless steel shelving system with overhead guiding rails, obstruction free floor with 40% gain in storage capacity. Modular shelving components shown on previous pages. Every 4 meter a fixed upright shelf is needed.



code	description
999SSRBTG100	Rolling base for top guided mob. shelving 1030 x 610mm 40 <sup>9</sup> / <sub>16</sub> " x 24"
999SSRBTG120	Rolling base for top guided mob. shelving 1230 x 610mm 48 <sup>7</sup> / <sub>16</sub> " x 24"
999SSRBTG140	Rolling base for top guided mob. shelving 1430 x 610mm 56 <sup>5</sup> / <sub>16</sub> " x 24"





## HDS - HIGH DENSITY STORAGE SHELVING SYSTEM - FLOOR GUIDED

High density stainless steel shelving system with floor guiding rails providing up to 50% additional storage capacity. Modular shelving components shown on previous pages.



### code

### description

999SSRBFG100 Rolling base for floor guided mob. shelving  
1030 x 610mm - 40<sup>9</sup>/<sub>16</sub>" x 24"



999SPRI40610 Spri basket 400x600x100h mm  
15<sup>3</sup>/<sub>4</sub>" x 23<sup>5</sup>/<sub>8</sub>" x 3<sup>15</sup>/<sub>16</sub>"

999SPRI40613 Spri basket 400x600x130h mm  
15<sup>3</sup>/<sub>4</sub>" x 23<sup>5</sup>/<sub>8</sub>" x 5<sup>1</sup>/<sub>8</sub>"

999SPRI40620 Spri basket 400x600x200h mm  
15<sup>3</sup>/<sub>4</sub>" x 23<sup>5</sup>/<sub>8</sub>" x 7<sup>7</sup>/<sub>8</sub>"

9992247 ISO polypropylene container  
600x400x50h mm

9992248 ISO polypropylene container  
600x400x100h mm

9992249 ISO polypropylene container  
600x400x200h mm

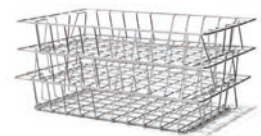

## CHROME SHELVING

Cost effective, easy to assemble modular chrome shelving available in 3 different lengths with 5 grid style shelves.

code	description
999CSS184274	Chrome shelving systems with 5 shelves 450 x 1050 x 1800 h mm - 17 <sup>3</sup> / <sub>4</sub> " x 41 <sup>5</sup> / <sub>16</sub> " x 70 <sup>7</sup> / <sub>8</sub> "
999CSS184874	Chrome shelving systems with 5 shelves 450 x 1220 x 1800 h mm - 17 <sup>3</sup> / <sub>4</sub> " x 47 <sup>1</sup> / <sub>4</sub> " x 70 <sup>7</sup> / <sub>8</sub> "
999CSS186074	Chrome shelving systems with 5 shelves 450 x 1520 x 1800 h mm - 17 <sup>3</sup> / <sub>4</sub> " x 59 <sup>13</sup> / <sub>16</sub> " x 70 <sup>7</sup> / <sub>8</sub> "
999CSS244274	Chrome shelving systems with 5 shelves 600 x 1050 x 1800 h mm - 23 <sup>5</sup> / <sub>8</sub> " x 41 <sup>5</sup> / <sub>16</sub> " x 70 <sup>7</sup> / <sub>8</sub> "
999CSS246074	Chrome shelving systems with 5 shelves 600 x 1520 x 1800 h mm - 23 <sup>5</sup> / <sub>8</sub> " x 59 <sup>13</sup> / <sub>16</sub> " x 70 <sup>7</sup> / <sub>8</sub> "
999CSS184286	Chrome shelving systems with 5 shelves 450 x 1050 x 2200 h mm - 17 <sup>3</sup> / <sub>4</sub> " x 41 <sup>5</sup> / <sub>16</sub> " x 86 <sup>5</sup> / <sub>8</sub> "
999CSS184886	Chrome shelving systems with 5 shelves 450 x 1220 x 2200 h mm - 17 <sup>3</sup> / <sub>4</sub> " x 47 <sup>1</sup> / <sub>4</sub> " x 86 <sup>5</sup> / <sub>8</sub> "
999CSS186086	Chrome shelving systems with 5 shelves 450 x 1520 x 2200 h mm - 17 <sup>3</sup> / <sub>4</sub> " x 59 <sup>13</sup> / <sub>16</sub> " x 86 <sup>5</sup> / <sub>8</sub> "
999CSS244286	Chrome shelving systems with 5 shelves 600 x 1050 x 2200 h mm - 23 <sup>5</sup> / <sub>8</sub> " x 41 <sup>5</sup> / <sub>16</sub> " x 86 <sup>5</sup> / <sub>8</sub> "
999CSS244886	Chrome shelving systems with 5 shelves 600 x 1220 x 2200 h mm - 23 <sup>5</sup> / <sub>8</sub> " x 47 <sup>1</sup> / <sub>4</sub> " x 86 <sup>5</sup> / <sub>8</sub> "
999CSS246086	Chrome shelving systems with 5 shelves 600 x 1520 x 2200 h mm - 23 <sup>5</sup> / <sub>8</sub> " x 59 <sup>13</sup> / <sub>16</sub> " x 86 <sup>5</sup> / <sub>8</sub> "
999CSSCLA000	Post clamp to connect separate consecutive shelving system units
999CSSH00K00	S-Hook to create continuous runs of shelving (straight or 90°) sharing the same posts





## STAINLESS STEEL FILING AND STORAGE CABINETS

TIG welded of AISI 304 stainless steel, available as a single or double door cupboard with 1 fixed and 4 adjustable shelves. Optionally fitted with impact resistant tempered glass door(s).

### Single door cabinets

code	description
999ST1145721	Stainless steel narrow single door cupboard with 1 fixed and 4 adjustable shelves 500 x 680 x 2100h mm 19 <sup>11</sup> / <sub>16</sub> " x 26 <sup>3</sup> / <sub>4</sub> " x 82 <sup>11</sup> / <sub>16</sub> "
999ST1146721	Stainless steel wide single door cupboard with 1 fixed and 4 adjustable shelves 600 x 680 x 2100h mm 23 <sup>5</sup> / <sub>8</sub> " x 26 <sup>3</sup> / <sub>4</sub> " x 82 <sup>11</sup> / <sub>16</sub> "
999ST1GLASS1	Supply and fitment of single glass door in lieu of steel door



### Double door cabinets

code	description
999STD141721	Stainless steel narrow double door cupboard with 1 fixed and 4 adjustable shelves 1000 x 680 x 2100h mm 39 <sup>3</sup> / <sub>8</sub> " x 26 <sup>3</sup> / <sub>4</sub> " x 82 <sup>11</sup> / <sub>16</sub> "
999STD142721	Stainless steel wide double door cupboard with 1 fixed and 4 adjustable shelves 1200 x 680 x 2100h mm 47 <sup>1</sup> / <sub>4</sub> " x 26 <sup>3</sup> / <sub>4</sub> " x 82 <sup>11</sup> / <sub>16</sub> "
999ST2GLASS2	Supply and fitment of double glass doors in lieu of steel doors
999STSL00000	Slope top for 680mm - 26 <sup>3</sup> / <sub>4</sub> " deep cabinet

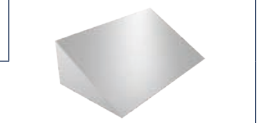

## PASS THROUGH CABINETS FOR BASKETS/CONTAINERS

TIG welded of AISI 304 stainless steel, available as a single or double door cupboard with 1 fixed and 4 adjustable shelves. Optionally fitted with impact resistant tempered glass door(s). Electronically governed door opening to prevent doors on both clean and sterile side being opened at the same time.

### Pass through cabinets with shelves

code	description
999ST1407721	Pass through cabinet with 1 fixed and 4 adjustable shelves 750 x 720 x 2100 H mm 29 <sup>1</sup> / <sub>2</sub> " x 28 <sup>3</sup> / <sub>8</sub> " x 82 <sup>11</sup> / <sub>16</sub> "
999ST1410721	Pass through cabinet with 1 fixed and 4 adjustable shelves 1000 x 720 x 2100 H mm 39 <sup>3</sup> / <sub>8</sub> " x 28 <sup>3</sup> / <sub>8</sub> " x 82 <sup>11</sup> / <sub>16</sub> "
999ST1412721	Pass through cabinet with 1 fixed and 4 adjustable shelves 1200 x 720 x 2100 H mm 47 <sup>1</sup> / <sub>4</sub> " x 28 <sup>3</sup> / <sub>8</sub> " x 82 <sup>11</sup> / <sub>16</sub> "
999ST4GLASS1	Supply and fitment of glass door for item 999ST1407721
999ST4GLASS2	Supply and fitment of double glass door for items 999ST1410721 and 999ST1412721



## PASS THROUGH CABINETS FOR TRANSPORT TROLLEYS

Double door pass through cabinets with glass doors, TIG welded of AISI 304 stainless steel. Standard equipped with floor barrier to avoid the transport trolley to enter into the sterile area.

### Pass through cabinets for transport trolleys

code	description
999PTCS12918	Pass through cabinet with with glass doors for standard width transport trolleys 1200 x 900 x 1800 H mm
999PTCW15918	Pass through cabinet with with glass doors for wide width transport trolleys 1500 x 900 x 1800 H mm

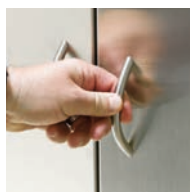



**Miele** Group  
Member

# Customization. Innovation. Excellence.

## **STEELCO - Miele Group Member**

Headquarters:  
Via Balegante, 27 - 31039  
Riese Pio X (TV) - Italy  
Ph. +39 0423 7561  
Fax +39 0423 75528  
info@steelcogroup.com  
[www.steelcogroup.com](http://www.steelcogroup.com)

### Branches:

STEELCO AUSTRIA  
Wals-Siezenheim, Austria  
info-at@steelcogroup.com

STEELCO BELGIUM  
Mollem, Belgium  
info-be@steelcogroup.com

STEELCO BENELUX  
Vianen, Netherlands  
info-benelux@steelcogroup.com

STEELCO CHINA  
Shanghai, China  
info-cn@steelcogroup.com

STEELCO FRANCE  
Paris, France  
info-fr@steelcogroup.com

STEELCO GERMANY  
Gütersloh, Germany  
info-de@steelcogroup.com

STEELCO HUNGARY  
Budapest, Hungary  
info-hu@steelcogroup.com

STEELCO MEXICO  
CDMX, Mexico  
info-mx@steelcogroup.com

STEELCO NORDIC  
Kgs. Lyngby, Denmark  
info-nordic@steelcogroup.com

STEELCO NORGE  
Nesbru, Norway  
info-no@steelcogroup.com

STEELCO SPAIN  
Madrid, Spain  
info-es@steelcogroup.com

STEELCO SWITZERLAND  
Spreitenbach, Switzerland  
info-ch@steelcogroup.com

STEELCO USA  
West Palm Beach, USA  
info-usa@steelcogroup.com

